

SANDWELL BATTERY-FREE SCALES



- Imperial and metric weight settings (kg or lb)
- 180kg maximum weight capacity
- Rubber feet
- Battery free operation

Specification

White & Clear Glass
1.30kg
6mm glass

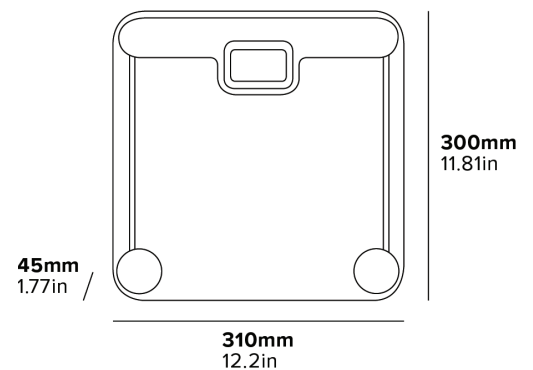



Hotel Supplies

PRODUCTS OF DISTINCTION

Proud Distributors of Luxurious Hotel Supplies

At Hotel Supplies Ltd, we provide a wide selection of high-quality products to elevate your guests' experience. From luxurious toiletries and cozy bathrobes to eco-friendly welcome amenities and tailored items, we cater to both small and large-scale requirements—whether it's for intimate boutiques or ambitious new hotel projects.

Family-run Business

Based in Surrey, Hotel Supplies Ltd is a family-run business with over 25 years of experience in the hospitality industry. Led by Stefan and Jenny, we pride ourselves on quality products and outstanding customer service. Stefan's extensive industry knowledge and commitment to excellence, combined with Jenny's attention to detail and passion for luxury, ensure our customers always receive the best.

Shop Now:



www.hotelsuppliesltd.co.uk



info@hotelsuppliesltd.co.uk



01372 725544

